



Valve Accessories & Controls.

## BLX Positioners

Dependable Products • Responsive Service



BLX V100 Series

# Years of experience have helped

## Introducing the BLX V100P and V100E positioners.

This new line of pneumatic and electropneumatic positioners incorporates over sixty years of design, manufacturing, and marketing experience, creating one of the most durable, reliable instruments on the market.



### Options

Special cams, range springs, various NEMA ratings, and feedback capability are components of the BLX positioner package.



### Flexibility

One housing for pneumatic or electropneumatic

The I/P can be installed or removed at any time

Multiple mounting capability

Standard indicator allows for air to open or air to close operation

Flat or raised indicator available

F05 standard housing with interchangeable drives.

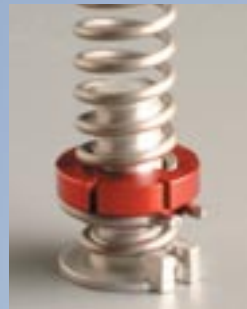

### Simple Calibration

With the non-interactive span and zero adjustment, and the external zero adjustment, calibration is simple and time saving.

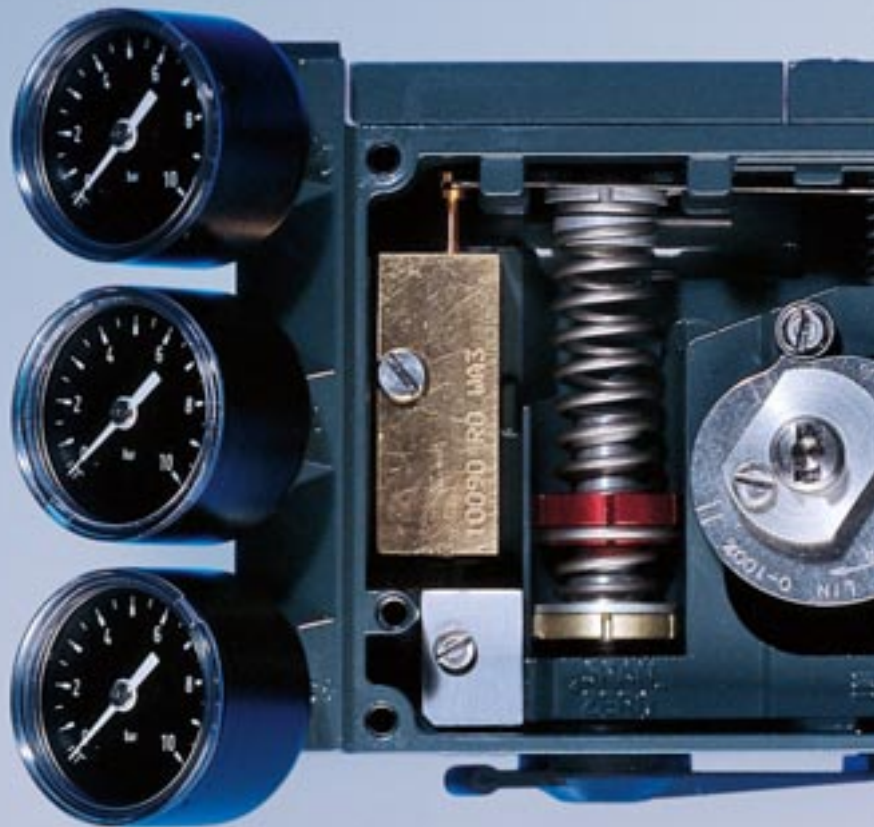

### Maintenance friendly

The BLX pilot valve assembly can be cleaned by removing one screw and can only be installed one way—the correct way.

The gauge block is standard

I/P test point facilitates positioner loop testing

# develop this complete positioner.

Dependable design supported with excellent service.

## Durable

Cast aluminum,  
Polyester coated  
housing

Stainless steel  
retained fasteners

Double locked  
stainless cam

Quality metal  
internal parts



Unique electrical  
compartment, fitted  
with an o-ring, is  
pressure sealed by  
the cover

## Technical Specifications

	V100P	V100E
Input range:	3-15 PSI (20-100kPa)	4-20 mA ( $R_i < 250\Omega$ )
Supply pressure:	<145 PSI (<1MPa)	21.8-145 PSI (0.15-1MPa)
Linearity error:	<0.7% f.s.	<1.0% f.s.
Hysteresis:	<0.4% f.s.	<0.6% f.s.
Repeatability:	<0.3% f.s.	<0.5% f.s.

### Pressure Gain:

@87 PSI (600kPa) acc. to ISA S75.13	$750 P_{out} / P_{in}$ $49\% P_{out} / \%P_{in}$
--	---

### Air Capacity:

	SCFM	(SLPM)
@29 PSI (200kPa)	9.5	(270)
@87 PSI (600kPa)	28.3	(800)
@145 PSI (1MPa)	47.1	(1350)

### Bleed Rate:

	SCFM	(SLPM)	SCFM	(SLPM)
@29 PSI (200kPa)	0.18	(5)	0.2	(5.7)
@87 PSI (600kPa)	0.53	(15)	0.6	(17.0)
@145 PSI (1MPa)	0.88	(25)	1.0	(28.3)

Temp range: -40° to 185° Fahrenheit  
-40° to +85° Celsius

Air connectors: 1/4" NPT (optional G threads)  
Gauges: 1/8" NPT  
Cable entry: 1/2" NPT (optional M20x1.5 or PG 13.5)

Ingress & corrosion protection: NEMA 4X and IP66  
Coating: Powder Polyester

Weight: 3.5 lbs (1.6kg)      3.8 lbs (1.7kg)  
Weight with gauges: 4.0 lbs (1.8kg)      4.2 lbs (1.9kg)

### Options:

Feedback Spring for 6-30PSI (40-200kPa) input signal.  
Gauges  
Various cams

### Pilot Valves:

Type W1 for better stability and lower bleed. Pressure gain @ 87 PSI = 300  
Bleeds 33% less but has 10% less air capacity than standard valve W3

Type W2 for faster response and better accuracy. Pressure gain @ 87 PSI > 1000  
Has same air capacity but bleeds 33% more than standard valve W3.

Above specifications are based on Type W3 as the standard pilot valve.

## Ordering Codes

Positioner	Type	Drive	Front Cover	Indicator	Cam
V100	P-Pneumatic E-Electropneumatic EX-Explosion Proof FF-Fail Freeze	D1-Namur D2- 1/2" square (others available)	90-90 degree 60-60 degree 45-45 degree 30-30 degree	A-arrow B-raised	C1-Standard-90° C2-45° & 90° C3-60° & 30° C4-120° & 60°

Example: V100E-D1-90-B-C1

Electropneumatic positioner, with namur drive, 90° cover, raised indicator, and standard 90° cam.

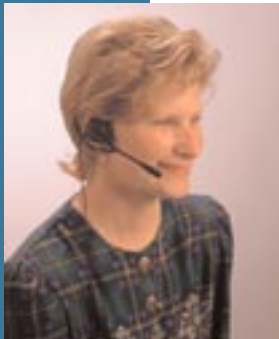
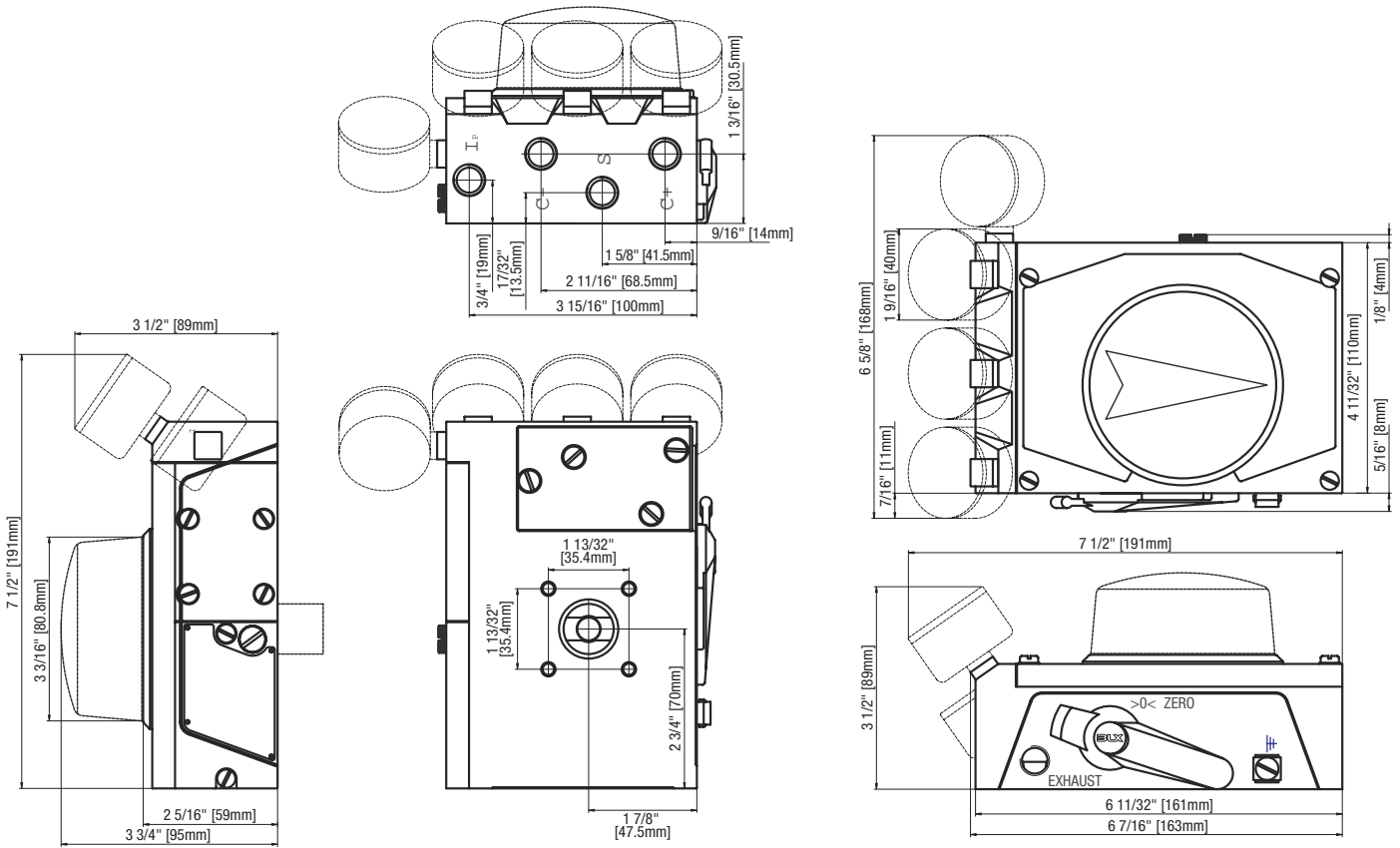

The BLX positioner line will be supported by a knowledgeable and professional staff. Customer service is a key component to the BLX package.

Local inventories and technical assistance are just a phone call away.

The BLX product package will include a diverse mix of positioners, rack and pinion actuators, and feedback switches for positioner mounting and/or stand alone use, as well as an I/P transducer. Quality design and manufacturing will be



coupled with very competitive pricing and excellent service,

providing all process industries a "complete package".

**CeeVee Ltd**

Units E7 & E8  
 Inchbrook Trading Estate,  
 Woodchester,  
 Stroud,  
 Glos.  
 GL5 5EY  
 Tel 01453 833148  
 info@cee-vee.co.uk

[www.cee-vee.co.uk](http://www.cee-vee.co.uk)