

A210 Series Pneumatic Actuators

Proval A210 Series innovative, compact design pneumatic rack and pinion rotary actuators including all critical components are manufactured in-house using dedicated state-of-the-art CNC machines following ISO quality assurance standards. Proval pneumatic actuators that can be set either to fail-open or fail-close, comes in 18 different sizes in both double and single acting types. This Series of actuators having torque figures in ranges 9 to 9767 Nm are well suited to operate part-turn valves such as plug, ball and butterfly valves.

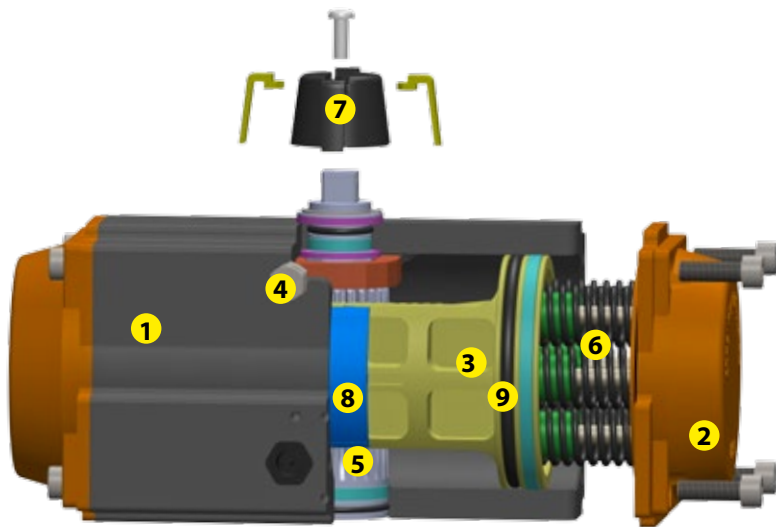

General Features

- Compact design
- Available in 18 different sizes
- Spring return or double acting versions
- High and Low temperature executions
- Common end caps on SR and DA
- Namur accessory mounting configuration
- Bi-directional stroke adjustment bolts
- Operating media - clean, dry air or non-corrosive gases
- Modular preloaded spring cartridges
- Durable, trouble free operation

1. Actuator Body

Heavy duty extruded aluminium body having a smooth surface finish is hard anodised both externally and internally to increase corrosion resistance and life span of internal parts. Different types of protective coatings, such as ENP, PFA and ECTFE allowing actuators to be used in harsh environments are available upon request.



2. End Caps

Epoxy powder coated die-cast aluminium end caps are identical for actuators in single and double acting configuration to facilitate conversion on site. Alternatively ENP, PFA, ECTFE etc coatings are available for highly aggressive environments.

3. Pistons

Die-cast aluminium pistons are treated with a special coating to decrease friction coefficient and increase wear resistance. The direction of pinion rotation (CCW to CW) can be changed by rotating the pistons 180° around their axis as the pistons installed at the both ends of the actuator are identical to each other.

4. Travel Adjustment

Each end of actuator travel (CW and CCW) can be adjusted by $\pm 5^\circ$ turning the right and left stroke adjustment bolts placed independently of each other, IN or OUT.

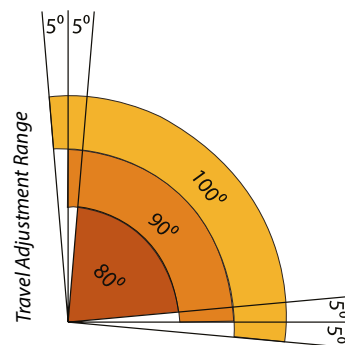
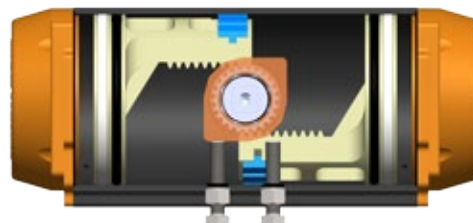

5. Pinion (Drive Shaft)

Alloy-steel shafts are designed and machined precisely in compliance with ISO5211, DIN3337, VDI/VDE 3845 standards. Plated in electroless nickel to provide substantially improved performance, wear and corrosion resistance in aggressive environments.

6. Preloaded Cartridge Springs

High grade steel spring cartridges are cathoporesis coated to provide highly improved safety and corrosion resistance in fail safe and emergency shut down operations.

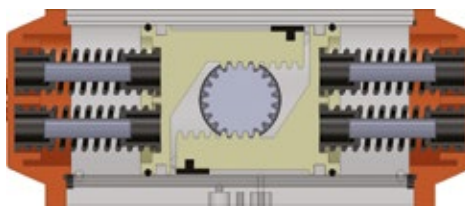

7. Indicator

All actuators are furnished with a local position indicator that provides visual indication of valve/actuator position.

8. Bearings & Guides

High quality, low friction bearings and guides to avoid metal-to-metal contact and ensure reliable and stable linear motion.

9. Seals

Actuators fitted with NBR o-rings are suitable for use at temperatures ranging from -20 °C to +80 °C. FKM and Silicon O-rings are available for low and high temperature executions.



10. Traceability

A unique Serial number is assigned to all actuators to facilitate identification and provide maximum traceability.

	PA TYPE PNEUMATIC ACTUATOR	
	Model Nr / Type : PA 052 DA ISO Flange / Sq. : F03/F05 - 11X11 Rotation / Stroke: CCW / 90° ± 5° Inlet Port : G 1/4" Op. Temperature: -20°C ~ 80°C Max Air Supply : 8 Bar Seal / Stem Mtrl : NBR / STL+ENP Body Finish : STANDARD Serial Number : 10140255	www.proval.net
CE II 2 GDc PC Made in Turkey	DISASSEMBLY WHILE PRESSURIZED WILL CAUSE SERIOUS INJURIES	

High quality, durable and self-adhesive stickers indicating temperature/pressurating limitations of actuators are affixed to actuators and need to be strictly considered when commissioning



A210 Series 90° Rotation Pneumatic Actuators Part List

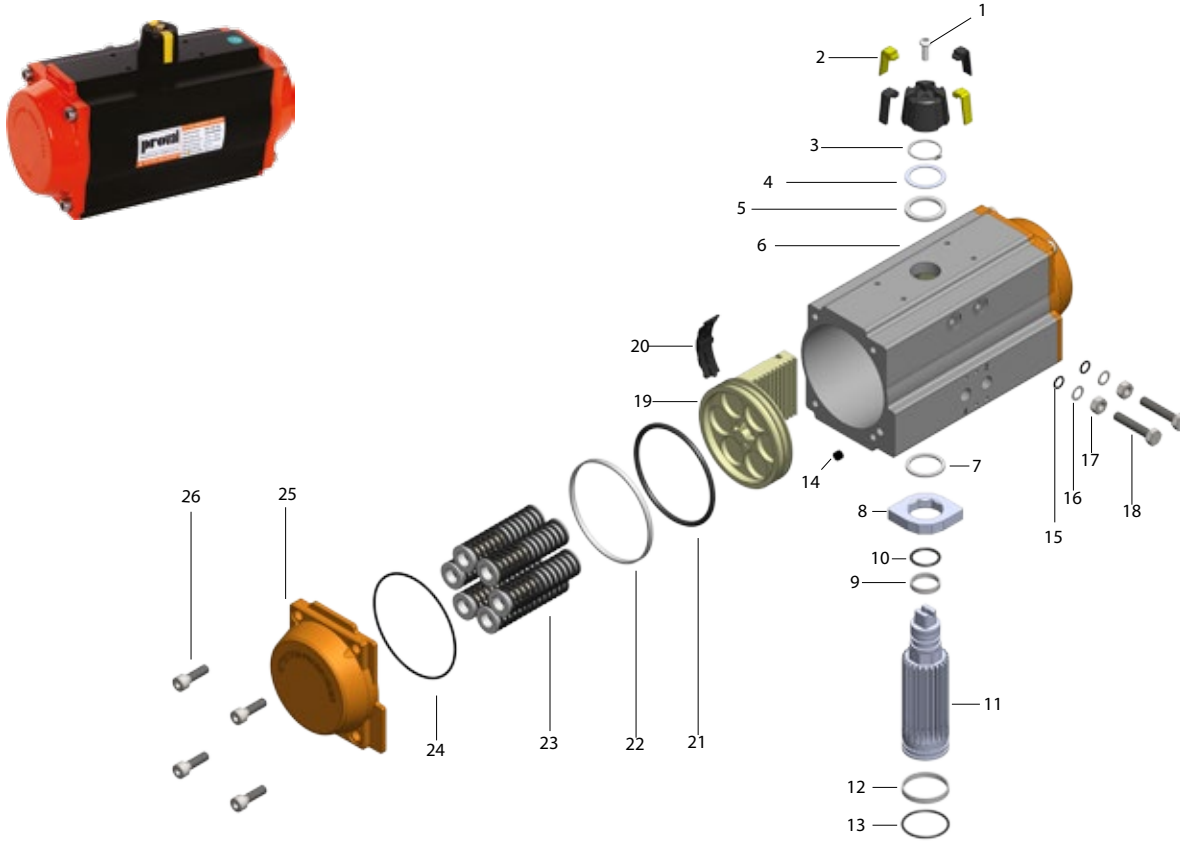

No.	Description	Qty	Standard Material	Protection	Optional Material
1	Indicator Screw	1	Stainless Steel	Galvanized Coating	Stainless Steel
2	Indicator	1	Plastic		
3	Circlip	1	Stainless Steel		
4	Metal Washer	1	Stainless Steel		
5	Washer	1	Engineering Plastics		
6	Body	1	Extruded Aluminium Alloy	Hard Anodizing	Stainless Steel , Epoxy / Nickel Coating
7	Inner Washer	1	Engineering Plastics		
8	Cam	1	Alloy Steel		
9	Pinion Upper Bearing	1	Engineering Plastics		
10	Pinion Upper O-Ring	1	NBR		
11	Pinion	1	Alloy Steel	Nickel Plating / Galvanized Coating	Stainless Steel
12	Pinion Lower Bearing	1	NBR		Viton/Silicon
13	Pinion Lower O-Ring	1	Engineering Plastics		
14	Sealing Plug	2	NBR		Viton/Silicon
15	Adjustment Screw O-Ring	2	NBR		Viton/Silicon
16	Washer (Adjustment Bolt)	2	Stainless Steel		
17	Nut (Adjustment Bolt)	2	Stainless Steel		
18	Stroke Adjustment Bolt	2	Stainless Steel		
19	Piston	2	Aluminium Die Cast	Alodine Coating	
20	Guide Piston	2	Engineering Plastics		
21	Piston Bearing	2	Engineering Plastics		
22	Piston O-Ring	2	NBR		Viton/Silicon
23	Cartridge Springs	0~12	Spring Steel	Cataphoresis Coating	
24	End Cap O-Ring	2	NBR		Viton/Silicon
25	End Cap	2	Cast Aluminium	Epoxy Powder Coatinga	Stainless Steel
26	Cap Screw	8	Stainless Steel		

A210 Series 90° Rotation Pneumatic Actuators Dimensions and Weight Information

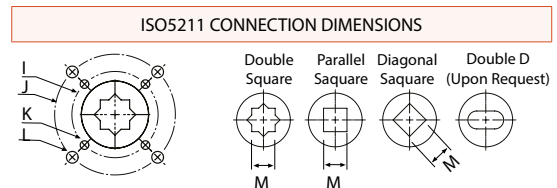
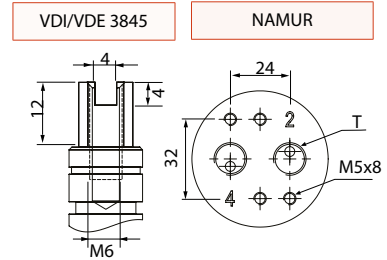
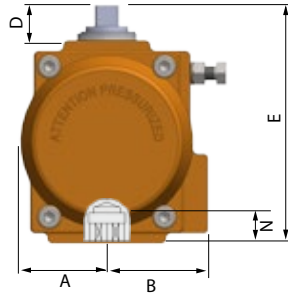
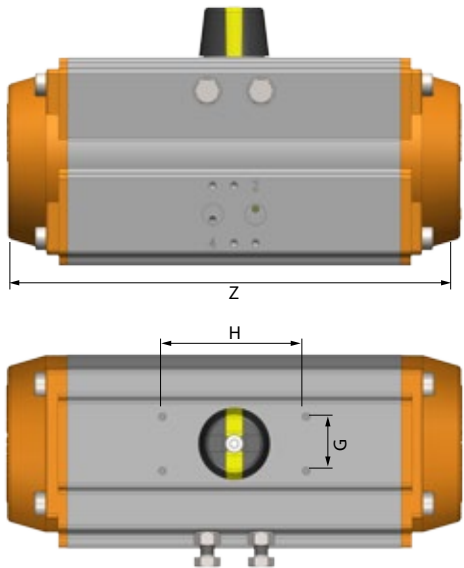

Dimensions(mm)

Model	A	B	D	E	G	H	I	J	K	L	M	N	Z	T
PA 32	23	23	20	65	25	50	ø36	-	M5x8	-	9	14	99	G1/8"
PA 40	40	36	20	81	30	80	ø36	ø50	M5x8	M6x10	11	14	124	G1/4"
PA 52	30	41	20	92	30	80	ø36	ø50	M5x8	M6x10	11	14	154	G1/4"
PA 63	36	47	20	107,5	30	80	ø50	ø70	M6x10	M8x13	14	18	166	G1/4"
PA 75	42	53	20	119,5	30	80	ø50	ø70	M6x10	M8x13	14	18	186	G1/4"
PA 83	46	57	20	128,7	30	80	ø50	ø70	M6x10	M8x13	17	21	205	G1/4"
PA 92	50	58	20	136,8	30	80	ø50	ø70	M6x10	M8x13	17	21	253	G1/4"
PA 105	57,5	64	20	153	30	80	ø70	ø102	M8x13	M10x16	22	26	268	G1/4"
PA 125	67,5	74,5	20	175	30	80	ø70	ø102	M8x13	M10x16	22	26	301	G1/4"
PA 140	75	77	20	191,5	30	80	ø102	ø125	M10x16	M12x20	27	31	392	G1/4"
PA 160	87	87	20	217	30	80	ø102	ø125	M10x16	M12x20	27	31	451	G1/4"
PA 190	103	103	30	260	30	130		ø140		M16x25	36	40	525	G1/4"
PA 210	113	113	30	285	30	130		ø140		M16x25	36	40	532	G1/4"
PA 240	130	130	30	318	30	130		ø165		M20x25	46	50	610	G1/4"
PA 270	147	147	30	356	30	130		ø165		M20x25	46	50	722	G1/4"
PA 300	140	173	30	382	30	130		ø165		M20x25	46	55	774	G1/2"
PA 350	164	195	30	438	30	130	ø165	ø254	M20x25	M16x25	46	50	912	G1/2"
PA 400	260	260	30	494	30	130	ø165	ø254	M20x25	M16x25	46	50	945	G1/2"

Actuator Unit Weights (Kg/Pc)

Model	PA 32	PA 40	PA 52	PA 63	PA 75	PA 83	PA 92	PA 105	PA 125	PA 140	PA 160	PA 190	PA 210	PA 240	PA 270	PA 300	PA 350	PA 400
Spring Return	-	-	1,5	2,2	2,9	3,6	5,5	6,7	10,4	14,4	23,3	46,1	53,1	73,3	115,9	130,00	234,40	360,40
Double Acting	0,5	0,7	1,4	2,1	2,7	3,3	5,0	5,9	9,0	12,0	19,0	39,1	44,1	59,0	93,6	110,00	186,50	289,00

Air Consumption of Actuators (Lt/Stroke)

Model	PA 32	PA 40	PA 52	PA 63	PA 75	PA 83	PA 92	PA 105	PA 125	PA 140	PA 160	PA 190	PA 210	PA 240	PA 270	PA 300	PA 350	PA 400
Opening (Lt)	0,03	0,06	0,12	0,21	0,30	0,43	0,64	0,88	1,4	2,2	3,2	5,4	6,8	9	14	23,8	35,1	52,6
Closing (Lt)	0,04	0,08	0,16	0,23	0,34	0,47	0,73	0,95	1,6	2,5	3,7	5,9	7,5	11	17	29,7	46,3	36

A210 Series 90° Rotation Double Acting Pneumatic Actuators Working Principles

A210 Series Double acting actuators require compressed air to be supplied in both opening and closing strokes.

The output torques generated by actuators in double acting configuration vary mainly depending on the cylinder diameter and air supply pressure; it is simply calculated by multiplying the piston area by pitch circle radius of the pinion and by the supply pressure.

As shown in the diagram at the right the double acting pneumatic actuators are capable of offering constant torque through the 90° full stroke

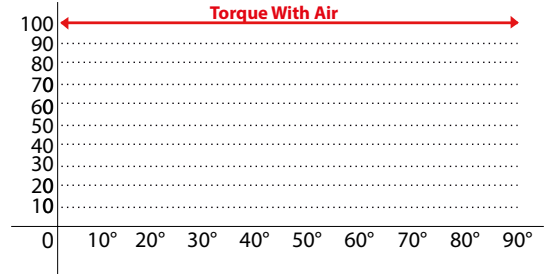

Torque Output Through Full 90° Stroke

Counter Clockwise Rotation (CCWR)

Air supplied through port B forces the piston towards each other causing the pinion to rotate clockwise while air is being exhausted through port A.

Air supplied through port A forces the piston away from each other causing the pinions to rotate counter clockwise while air is being exhausted through port B.

Clockwise Rotation (CWR)

Air supplied through port B forces the piston towards each other causing the pinion to rotate counter clockwise while air is being exhausted through port A.

Air supplied through port A forces the piston away from each other causing the pinions to rotate clockwise while air is being exhausted through port B.

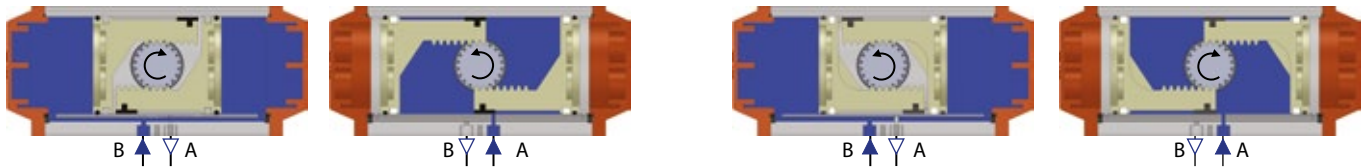

The Proval actuators typically operate counter clockwise to open and clockwise to close. The direction of pinion rotation (CCW to CW) can be reversed changing the orientation of pistons as shown in the picture above.

Double Acting Actuators Torque Values (Nm)

Model	Air Supply Pressure (bar)									
	2	2,5	3	4	4,5	5	5,5	6	7	8
PA 32DA	2	3,5	4	6	7	7,5	8	9	10	12
PA 40DA	6	8	10	13	14	16	18	20	22	26
PA 52DA	8	10	12	16	18	20	22	24	28	32
PA 63DA	15	19	22	30	33	37	40	44	52	58
PA 75DA	20	26	30	40	45	50	55	60	70	80
PA 83DA	33	40	48	63	71	79	86	94	110	125
PA 92DA	45	57	68	90	102	113	124	136	158	182
PA 105DA	66	83	100	132	149	166	182	200	232	265
PA 125DA	101	126	151	202	226	252	276	301	352	402
PA 140DA	171	214	257	342	385	428	471	513	599	684
PA 160DA	266	333	399	532	600	665	732	798	932	1064
PA 190DA	426	532	639	852	958	1064	1170	1277	1490	1702
PA 210DA	532	665	798	1064	1198	1330	1463	1596	1862	2128
PA 240DA	770	962	1155	1540	1732	1924	2117	2309	2693	3078
PA 270DA	1169	1462	1755	2340	2632	2925	3217	3510	4095	4680
PA 300DA	1526	1908	2289	3052	3434	3815	4197	4578	5341	6104
PA 350DA	2285	2856	3427	4570	5141	5712	6283	6854	7997	9139
PA 400DA	3256	4069	4883	6511	7325	8139	8953	9767	11394	13022

A210 Series 90° Rotation Spring Return Pneumatic Actuators Working Principles

Spring return actuators require compressed air to be supplied for the opening stroke only as they utilize pre-stressed cartridge springs for reversing the rotation.

Unlike acting actuators the output torques generated by spring return actuators depends not only on the cylinder diameter and input air pressure but also on the force created by the springs. Therefore spring return actuators are larger than the double acting actuators that produce the same torque.

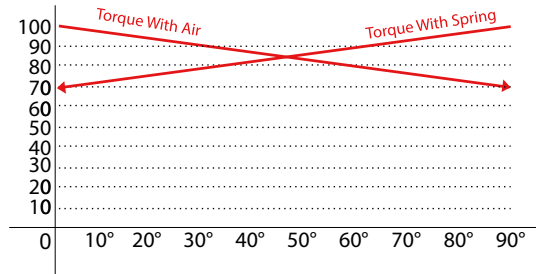

As shown in the diagram at the right, the torque curve is a straight line sloping down due to preloaded springs.

Counterclockwise Rotation (FAIL CW)

Air supplied through port A forces the piston away from each other, compressing springs and causing the pinion to rotate counter clockwise while air is being exhausted through port B.

In case of loss/release of air pressure, springs forces the pistons towards each other causing the pinion to rotate counter clockwise with exhaust air existing through port A.

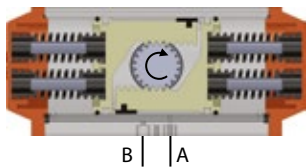
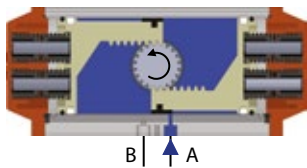

Clockwise Rotation (CWR)

Air supplied through port A forces the pistons away from each other, compressing springs and causing the pinion to rotate clockwise while air is being exhausted through port B.

In case of loss/release of air pressure, springs forces the pistons towards each other causing the pinion to rotate counter clockwise with exhaust air existing through port A.

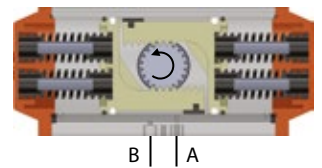
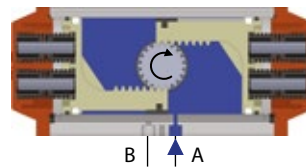

The proval actuators are preset for fail closed (CW) operation as standard, but can be adjusted easily for fail open (CCW) rotation.

Positioning of Springs for Spring Return Actuators

Springs must be inserted in a symmetrical manner as shown below to prevent side load from occurring between the pistons and actuators

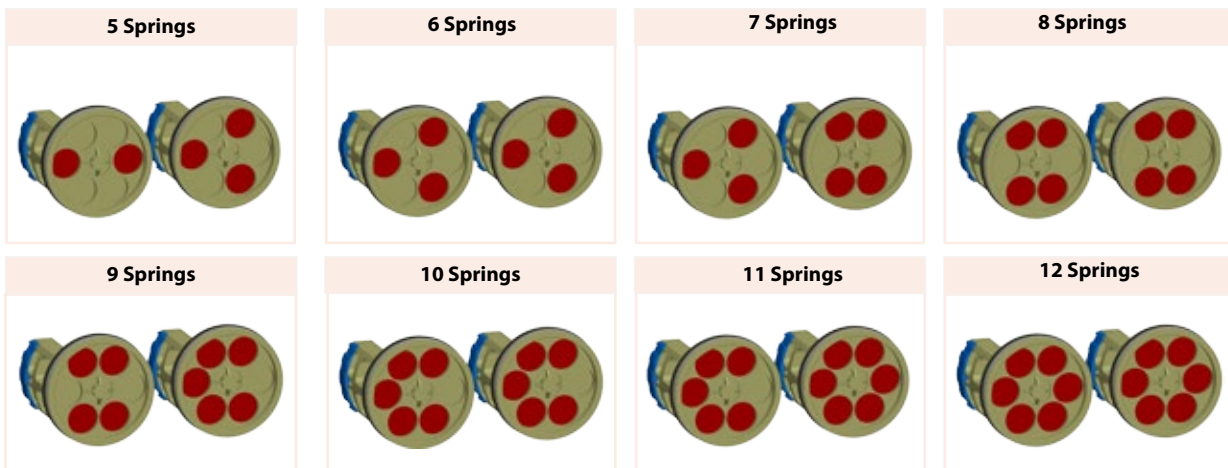

Unless otherwise specified, Proval pneumatic actuators supplied as standard with a complete spring pack (12 springs) sized for 6 bar supply pressure. For different air supplies, actuators can be configured by removing springs from the end caps.



A210 Series 90° Rotation Single Acting Actuators Torque Output Values (Nm)

		Air to Springs Torque Output Values (Nm)														Spring Torque (Nm)	
Air Supply	Nrof Springs	2,5 Bar		3 Bar		4 Bar		5 Bar		6 Bar		7 Bar		8 Bar		90°	0°
Model		0°	90°	0°	90°	0°	90°	0°	90°	0°	90°	0°	90°	0°	90°		
		Start	Stop	Start	Stop	Start	Stop	Start	Stop	Start	Stop	Start	Stop	Start	Stop	Start	Stop
PA 52SR	5	5,7	3,8	7,6	5,7											6,2	4,3
	6	4,9	2,5	6,9	4,5	10,9	8,5									7,4	5
	7	4	1,3	6	3,3	9,8	7,3	14	10,4							8,6	5,9
	8			5,2	2	9,2	6	13,2	9,1	17,2	14,1					9,9	6,7
	9			4,3	0,8	8,3	4,8	12,3	7,9	16,3	12,8	20,3	16,8			11,1	7,6
	10					7,4	3,6	11,5	6,7	15,5	11,6	19,5	15,6			12,4	8,5
	11					6,6	2,3	10,6	5,4	14,6	10,4	18,6	14,3	22,6	18,3	13,6	9,3
	12							9,7	4,2	13,8	9,1	17,8	12,2	21,8	17,1	14,8	10,2
PA 63SR	5	11,4	7,7	15	11,4	22,3	16,6									10,4	6,8
	6	10,1	5,7	13,6	9,3	20,9	14,9	28,3	23,9							12,5	8,2
	7	8,6	3,6	12,5	7,2	19,5	14,5	26,8	21,9							14,6	9,6
	8			10,9	5,1	18,2	12,4	25,5	19,8	32,8	27	40,1	34,3			16,7	10,9
	9					16,8	10,4	24,1	17,7	31,4	24,9	38,7	32,2			18,8	12,3
	10					1,4	8,2	22,8	15,6	30	22,8	37,3	30,1	44,7	37,4	20,9	13,7
	11							21,5	13,5	28,7	20,7	36	28	43,3	35,3	22,9	15
	12						20	11,4	27,3	18,6	34,6	25,9	41,9	33,3	25	16,4	
PA 75SR	5	14,5	10,6	19,4	15,5	29,5	25,7									14,5	10,5
	6	12,4	7,6	17,3	12,6	27,4	22,7	37,5	32,8							17,4	12,7
	7	10,4	4,8	15,2	9,7	25,3	19,9	35,4	29,9							20,3	14,8
	8			13,1	6,8	23,1	16,9	33,3	27	43,2	37	53,3	47			23,2	16,9
	9					21	14,1	31,2	24,1	41,1	34,1	51,2	44,2			26,1	19
	10					19	11,1	28,8	21,2	39	31,2	49,1	41,2	59,1	51,2	29	21,1
	11							27	18,3	37	28,3	47	38,4	57	48,4	31,9	23,2
	12						24,9	15,4	34,9	25,4	44,9	35,4	54,9	45,4	34,7	25,3	
PA 83SR	5	23,3	16,1	31,1	24	46,8	39,7									23	15,8
	6	20,1	11,5	28	19,3	43,7	35,1	59,4	50,7							27,6	19
	7	17	6,9	24,8	14,8	40,5	30,5	56,2	46,2							32,2	22,1
	8			21,7	10,1	37,4	25,8	53,1	41,5	68,8	57,2	84,5	72,9			36,8	25,3
	9					34,2	21,3	49,9	37	65,6	52,6	81,2	68,3			41,4	28,5
	10					31	16,6	46,7	32,3	62,4	48	78,1	63,7	93,8	79,3	46	31,6
	11							43,6	27,7	59,3	43,4	75	59,1	90,6	74,8	50,6	34,8
	12						40,4	23,2	56,1	38,9	71,7	54,5	87,4	70,2	55,2	38	
PA 92SR	5	33,1	22	44,2	33,2	66,8	55,9									34,4	23,3
	6	28,4	15,2	39,6	26,4	62,2	49	84,8	71,6							41,2	28
	7	23,8	8,2	34,9	19,4	57,5	42,1	80,2	64,7							48,1	32,7
	8			31,3	12,6	52,9	35,2	75,5	57,9	98,1	80,5	120,7	103			55	37,3
	9					48,2	28,4	70,9	51	93,5	73,6	116	96,1			61,9	42
	10					43,6	21,5	66,2	44,1	88,8	66,7	111,3	89,2	134	111,8	68,7	46,7
	11							61,5	37,2	84,1	59,9	106,6	82,4	129,2	105	75,6	51,4
	12						56,8	30,4	79,4	53	101,9	75,5	124,5	98,1	82,5	56	
PA 105SR	5	51	33,4	67,5	49,9	100,6	83									49,2	31,6
	6	44,7	23,5	61,1	40	94,2	73,2	127,3	106,2							59,1	38
	7	38,4	13,7	54,9	30,3	87,9	63,4	121	96,4							68,9	44,3
	8			48,5	20,4	81,6	53,5	114,7	86,5	147,7	119,6	180,8	152,7			78,7	50,6
	9					75,3	43,7	108,4	76,8	141,5	109,8	174,5	142,9			88,6	56,9
	10					68,9	33,4	102	66,5	135,1	99,6	168,2	132,6	201,2	165,7	98,4	63,3
	11							95,7	57	128,7	90,1	161,8	123,1	194,8	156,2	108,3	69,6
	12						89,4	47,5	122,5	80,6	155,5	113,6	188,6	146,7	118,1	75,9	
PA 125SR	5	73	47	98	72	148	122									79	52
	6	63	31	88	56	138	107	188	157							94	63
	7	52	15	77	40	127	90	178	141							110	73
	8			67	25	117	75	167	125	217	176	268	226			125	84
	9					107	59	157	109	207	159	257	210			141	94
	10					96	44	146	94	196	144	247	194	297	245	157	105
	11							136	78	186	128	236	178	286	228	173	115
	12						125	63	176	113	226	163	276	213	188	125	
PA 140SR	5	128	85	171	127	256	213									129	86
	6	111	59	154	102	239	187	325	273							155	103
	7	94	33	137	76	222	162	308	247							181	120
	8			120	50	205	136	291	221	376	307	462	392			206	137
	9					187	110	273	196	358	281	444	367			232	155
	10					170	84	256	169	341	255	427	340	512	426	258	172
	11							238	143	324	229	409	314	495	400	284	189
	12						221	118	307	203	392	289	478	374	310	206	

A210 Series 90° Rotation Single Acting Actuators Torque Output Values (Nm)

		Air to Springs Torque Output Values (Nm)														Spring Torque (Nm)	
Air Supply	Nr of Springs	2,5 Bar		3 Bar		4 Bar		5 Bar		6 Bar		7 Bar		8 Bar		90°	0°
Model		0°	90°	0°	90°	0°	90°	0°	90°	0°	90°	0°	90°	0°	90°		
		Start	Stop	Start	Stop	Start	Stop	Start	Stop	Start	Stop	Start	Stop	Start	Stop	Start	Stop
PA 160SR	5	193	124	259	191	392	324									208	140
	6	165	83	232	149	365	282	498	415							250	168
	7	137	41	203	107	336	240	469	373							292	196
	8			176	66	309	199	442	290	575	465	708	598			333	223
	9					280	157	413	237	546	423	679	556			375	251
	10					253	115	386	248	519	381	652	514	786	647	417	279
	11								358	207	491	340	624	473	757	606	458
	12							330	165	463	298	596	431	729	564	500	335
PA 190SR	5	332	222	438	329	651	542									309	200
	6	292	161	398	267	611	480	824	693							371	240
	7	252	99	358	205	571	418	784	631							433	280
	8			318	143	531	356	744	569	957	782	1169	995			495	320
	9					491	295	704	507	917	720	1130	933			557	360
	10					451	233	664	446	877	658	1090	871	1302	1084	618	400
	11							624	384	837	597	1050	809	1263	1022	680	440
	12							584	322	797	535	1010	748	1223	960	742	480
PA 210SR	5	390	285	523	418	789	684									380	275
	6	335	209	468	342	734	608	1000	874							456	330
	7	280	133	413	266	679	532	945	798							532	385
	8			358	190	624	456	890	722	1156	988	1422	1254			608	440
	9					569	380	835	646	1101	912	1367	1178			684	495
	10					514	304	780	570	1046	836	1312	1102	1578	1368	760	550
	11							725	494	991	760	1257	1026	1523	1292	836	605
	12							670	418	936	684	1202	950	1468	1216	912	660
PA 240SR	5	552	409	744	600	1129	985									554	410
	6	470	297	662	489	1047	874	1432	1259							665	492
	7	388	187	580	379	964	764	1349	1149							775	575
	8			498	268	883	653	1267	1037	1652	1422	2037	1807			886	656
	9					800	542	1185	926	1569	1311	1954	1696			998	739
	10					718	431	1103	816	1488	1201	1872	1586	2257	1970	1108	821
	11							1021	705	1406	1090	1791	1474	2176	1859	1219	903
	12							939	594	1323	979	1708	1363	2093	1748	1330	985
PA 270SR	5	903	675	1195	968	1779	1552									787	560
	6	790	519	1083	811	1667	1396	2252	1981							943	672
	7	679	361	972	654	1556	1238	2141	1823							1101	783
	8			860	497	1444	1081	2029	1666	2614	2252	3199	2836			1258	895
	9					1332	923	1917	1509	2502	2094	3087	2678			1416	1007
	10					1220	767	1805	1352	2390	1937	2974	2521	3560	3107	1572	1119
	11							1693	1194	2278	1779	2862	2364	3448	2949	1730	1231
	12							1582	1037	2167	1623	2751	2207	3336	2792	1887	1342
PA 300SR	5	1097	729													1061	730
	6	935	494	1316	875											1273	876
	7	772	258	1153	639	1916	1402									1485	1022
	8			991	403	1754	1166	2517	1929							1697	1168
	9					1592	930	2355	1693	3118	2456					1909	1213
	10					1430	695	2193	1458	2956	2221	3719	2984	4482	3747	2122	1460
	11							2030	1222	2793	1985	3556	2748	4319	3511	2334	1606
	12							1868	986	2631	1749	3394	2512	4157	3275	2546	1752
PA 350SR	5	1553	964													1702	1173
	6	1292	586	1863	1157											2043	1408
	7	1031	208	1602	779	2745	1929									2383	1642
	8			1341	401	2484	1544	3626	2686							2724	1877
	9					2224	1165	3366	2307	4508	3449					3064	2112
	10					1936	787	3105	1929	4247	3071	5390	4214	6532	5356	3405	2346
	11							2804	1551	3986	2693	5129	3836	6271	4978	3745	2581
	12							2584	1172	3726	2314	4869	3457	6011	4599	4086	2816
PA 400SR	7	2028	869													2880	1837
	8	1736	411	2550	1225											3292	2100
	9			2259	768	3887	2396									3703	2362
	10			1967	311	3595	1939	5223	3567							4115	2624
	11					3303	1482	4931	3110	6559	4738					4526	2887
	12					3012	1025	4640	2653	6268	4281	7895	5908	9523	7536	4938	3149
	13							4348	2195	5976	3823	7603	5450	9231	7078	5349	3412
	14							4057	1738	5685	3866	7312	4993	8940	6621	5761	3674
	15							3765	1281	5393	2909	7020	4536	8648	6164	6172	3937
	16									5101	2452	6728	4079	8356	5707	6584	4199